

RANGER MINI 3.0 User Manual



RANGER MINI 3.0

AgileX Robotics Team

USER MANUAL V.1.0.0 2024.06

Document version

No.	Version	Date	Edited by	Reviewer	Notes
1	V1.0.0	2024/6/25	Cynthia		First version

Before using the robot, any individual or organization must read and understand the manual. If you have any questions about it, please do not hesitate to contact us at support@agilex.ai. It is very important that you should follow and implement all instructions and guidelines in this manual. Please pay extra attention to the warnings.

Important Safety Information

This manual does not cover the design, installation, and operation of a robotic application, nor does it include any equipment that may affect the safety of a robotic system. A robot system that uses the RANGER MINI 3.0 should be designed and used in compliance with the safety requirements and other standards of the corresponding countries.

Any users of the RANGER MINI 3.0 should comply with laws and regulations of relevant countries and ensure that there are no obvious hazards in the application of the RANGER MINI 3.0. This includes but is not limited to the following:

Effectiveness and responsibility

- Do a risk assessment of the robotic system that uses the RANGER MINI 3.0.
- The risk assessment should include additional safety equipment to other machinery.
- Please ensure that the equipment of the whole robotic system, including software and hardware, are designed, and installed correctly.
- The RANGER MINI 3.0 is not an autonomous mobile robot with anti-collision, anti-fall, biological approach warning, and other safety functions. These safety functions are expected to be developed and assessed by system integrators and end customers under relevant safety regulations and laws to ensure there are not any major dangers and potential safety hazards in their practical applications.
- Read all technical documents: including the risk assessment and this manual.
- Know the possible safety risks before using the RANGER MINI 3.0.

Use Environment

- For the first use, please read this manual carefully to understand the basic operation and operating specifications.
- Remote control operation should be in a relatively open area. The RANGER MINI 3.0 does not have any automatic obstacle avoidance sensors.
- Please use the RANGER MINI 3.0 under the ambient temperature of -10 °C~40°C.
- The RANGER MINI 3.0's waterproof and dustproof level is IP54 if it is not customized.

Check

- Make sure each device is fully charged.
- Make sure the RANGER MINI 3.0 has no obvious abnormalities.
- Make sure the remote control has sufficient battery power.

Precautions

Operation Precautions

- Ensure that the surrounding area is relatively open when operating the RANGER.
- Please do remote control within sight.
- The maximum load of the RANGER MINI 3.0 is 100 KG. Please ensure that the payload does not exceed 100 KG when using.
- When installing external equipment on the RANGER MINI 3.0, Please ensure their centroid location is at the RANGER MINI 3.0's center of rotation.
- Please charge the RANGER MINI 3.0 in time after low-battery alarm.
- When the RANGER MINI 3.0 is abnormal, please stop using it immediately to avoid secondary injury.

- When the RANGER MINI 3.0 is abnormal, please contact the technical support immediately, and do not handle it without professional suggestion.
- Please use the RANGER MINI 3.0 in an environment that does not exceed its IP protection level.
- Do not push the RANGER MINI 3.0 directly.
- The current of the tail extension power supply does not exceed 15A, and the total power does not exceed 720w.

Battery

- The battery of RANGER MINI products is not fully charged when it leaves the factory. The specific battery voltage and power can be displayed through vol and batt on the RANGER MINI remote control.
- Please do not charge the battery after it is exhausted, please charge it in time when the low battery of the RANGER MINI remote control is less than 15%
- Static storage conditions: The optimal storage temperature is -10°C~40°C. When the battery is not in use, it must be charged and discharged once every month, and then stored at full voltage. Do not store the battery Place in fire, or heat the battery. Do not store batteries at high temperatures.
- Charging: You must use the matching lithium battery charger for charging. Do not charge the battery below 0°C. Do not use non-original standard batteries, power supplies, and chargers.

Usage environment

- The operating temperature of RANGER MINI is -10°C~40°C, please do not use it in an environment where the temperature is lower than -10°C and higher than 40°C
- Do not use it in an environment with corrosive or flammable gases or near flammable substances.
- Please do not use it around heating elements such as heaters or large winding resistors
- RANGER MINI is waterproof and dustproof rated IP54
- It is recommended that the altitude of the use environment should not exceed 1000M
- It is recommended that the temperature difference between day and night in the use environment does not exceed 25°C

Safety

- If you have any questions about the use process, please follow the relevant instruction manual or consult relevant technical personnel.
- Before using the equipment, pay attention to the on-site conditions to avoid improper operation that may cause personal safety problems.
- In case of emergency, press the emergency stop button to power off the equipment.
- Do not modify the internal equipment structure without technical support and permission
- When the equipment is abnormal, please stop using it immediately to avoid secondary injury
- When an abnormality occurs in the equipment, please contact the relevant technical personnel and do not handle it without authorization.

CONTENTS

CONTENTS

Document version

Important Safety Information

Precautions

CONTENTS

1 Introduction to the RANGER MINI 3.0

- 1.1 Product List
- 1.2 Specifications
- 1.3 Required for Development

2 Basic Introduction

- 2.1 Status of the RANGER MINI 3.0
- 2.2 Description of Electrical Interfaces
- 2.3 Remote Control Instructions

3 Usage and Development

- 3.1 Operation
- 3.2 CAN Communication Protocol
- 3.3 RANGER MINI 3.0 use manual for ROS
- 3.4 Firmware Upgrade

4 Product Size

1 Introduction to the RANGER MINI 3.0

The RANGER MINI 3.0 is a programmable omnidirectional UGV (UNMANNED GROUND VEHICLE), which is a chassis with a modular design. Compared with the four-wheel differential chassis, the RANGER MINI 3.0 has obvious advantages when running on ordinary cement roads and asphalt roads. It not only has higher speed and load capacity, but also reduces the wear and tear on the structure and tires. It is also more stable and safer. Compared with Ackermann chassis, the RANGER MINI3.0 not only reduces the turning radius, but also can turn at 0 angle. The RANGER MINI 3.0 combines the advantages of differential chassis and Ackermann chassis, which is suitable for various complex terrains. What's more, it can be equipped with stereo cameras, LiDAR, GNSS, IMU, manipulators and other equipment to be applied in fields such as unmanned inspection, security, scientific research, exploration and logistics.

1.1 Product List

Name	Quantity
RANGER MINI 3 body	×1
Battery charger (AC 220V)	×1
Aviation plug male (4Pin)	×1
FS remote controller (optional)	×1
USB to CAN communication module	×1

1.2 Specifications

Type	Items	Parameters
Mechanical	Dimensions (mm)	720×500×345
	Axle Track (mm)	494
	Front/rear track (mm)	364
	Total weight (Kg)	75
	Battery type	Lithium iron phosphate
	Battery parameters	48V24AH
	Power drive motor	350W×4
	Steering drive motor	100W×4
	Parking type	Electronic brake
	Steering type	4 wheels steering
	Suspension	Independent suspension
	Steering motor reduction ratio	1:51
	Steering motor encoder	Dual Encoder
	Drive motor reduction ratio	1:4.428
	Drive motor sensor	Encoder
Performance	IP grade	IP54

	Maximum speed (km/h)	7.2
	Minimum turning radius (mm)	0mm (Spin mode) 810mm (Ackermann model)
	Maximum climbing ability (°)	15° (25kg)
	Crossing width	120mm
	Ground clearance (mm)	105
	Maximum endurance (h)	7
	Maximum travel (km)	35
	Charging time (h)	1.5
	Working temperature (°C)	-10~40
Control	Control mode	Remote control mode Command control mode
	Remote controller	2.4G/limit distance 100M
	Communication Interface	CAN

1.3 Required for Development

The RANGER MINI 3.0 can be equipped with FS remote control when buying. Users can use it to control the 4WD chassis, complete mode switching, movement and steering. The RANGER MINI 3.0 has a standard CAN (Controller Area Network) communication interface to facilitate secondary development.

2 Basic Introduction

This part is a basic introduction to the RANGER MINI 3.0, mobile robot chassis. After reading this part, users and developers can have an overall understanding about it. As shown in Figure 2.1 below, it is an overview of the RANGER MINI 3.0,.

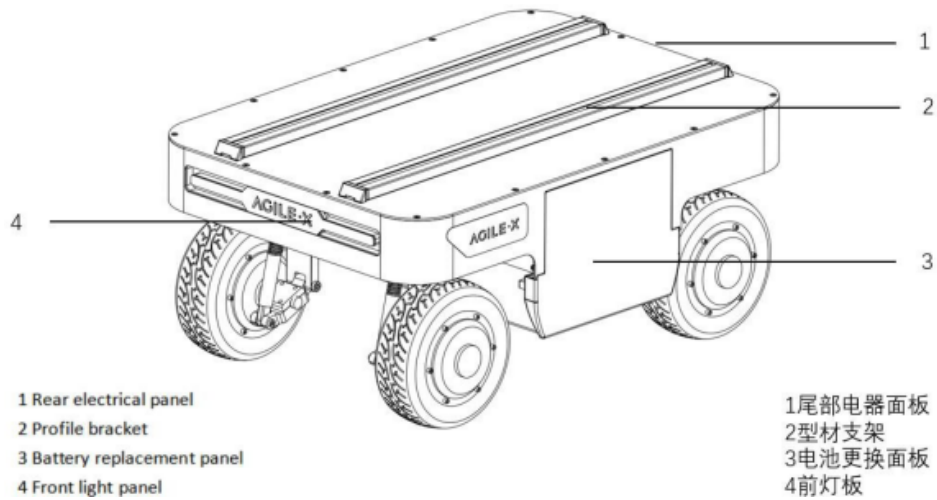

Figure 2.1 Overview of the RANGER MINI 3.0

The RANGER MINI 3.0 is based on a modular and intelligent design concept. It adopts a composite design of solid tires and swing arms on the power module, and has a powerful hub motor, which makes the RANGER MINI 3.0 swift passing ability and ground adaptability. It can move flexibly on different ground. The hub motor does not require complicated transmission design, making the RANGER MINI 3.0 smaller and more flexible. An open electrical interface and communication interface are configured at the rear of the RANGER MINI 3.0, which is convenient for users to carry out secondary development. The electrical interface adopts aviation waterproof connectors, which is not only conducive to the expansion and use, but also allows the RANGER MINI 3.0 to be used in some harsh environments. A standard aluminum extension bracket is installed on the RANGER MINI 3.0, which is convenient for users to carry external equipment.

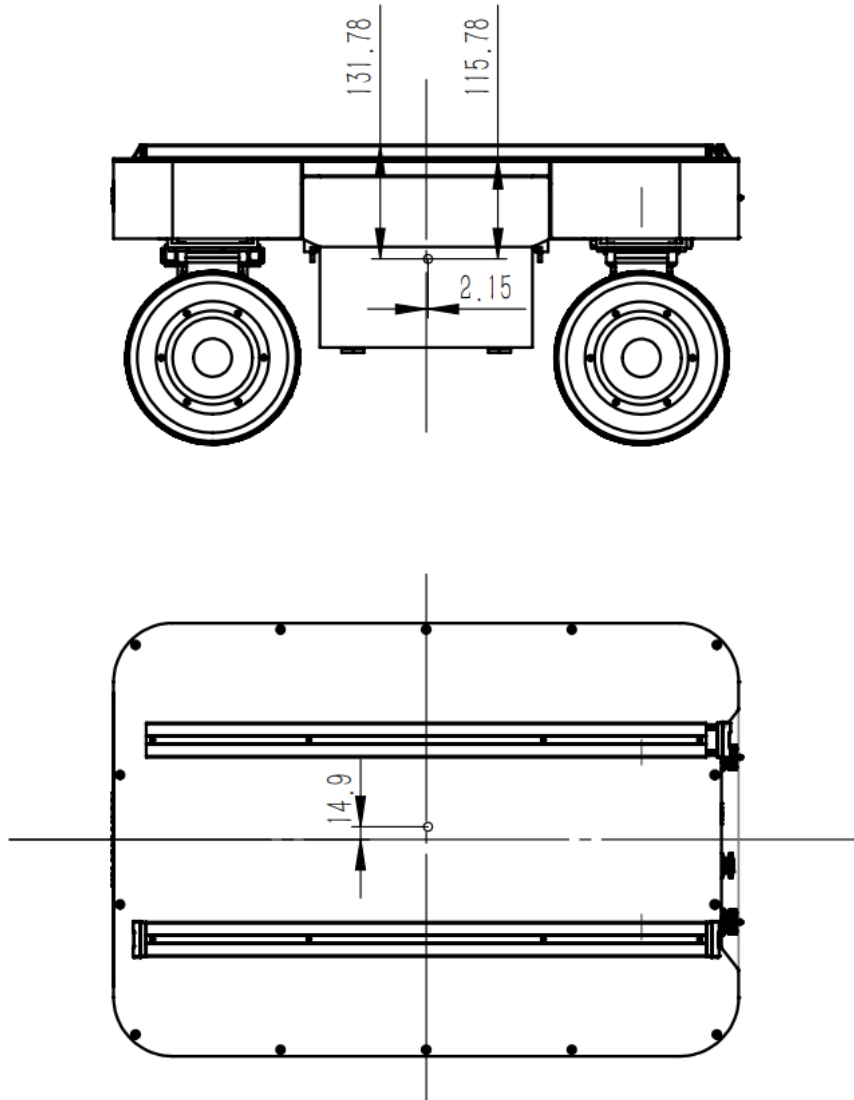

Figure 2.2 Gravity center of RANGER MINI 3.0

2.1 Status of the RANGER MINI 3.0

The user can check the status of the RANGER MINI 3.0 through its CAN message. Please refer to Table 2.1 for specific status.

Status	Description
Current Voltage	The current battery voltage and power can be viewed through vol and batt on the remote controller.
Low Voltage Warning	When the SOC (State of Charge) of the battery is lower than 15% through BMS feedback, the front and rear lights of the RANGER MINI 3.0 will flash as a reminder. When the battery power is detected lower than 10%, the chassis will actively cut off the power supply for external equipment and driver to protect the battery. At this time, the chassis will not move and accept external command control.

Detailed Status Information	Check by CAN message
-----------------------------	----------------------

Table 2.1 Status Description Table for the RANGER

2.2 Description of Electrical Interfaces

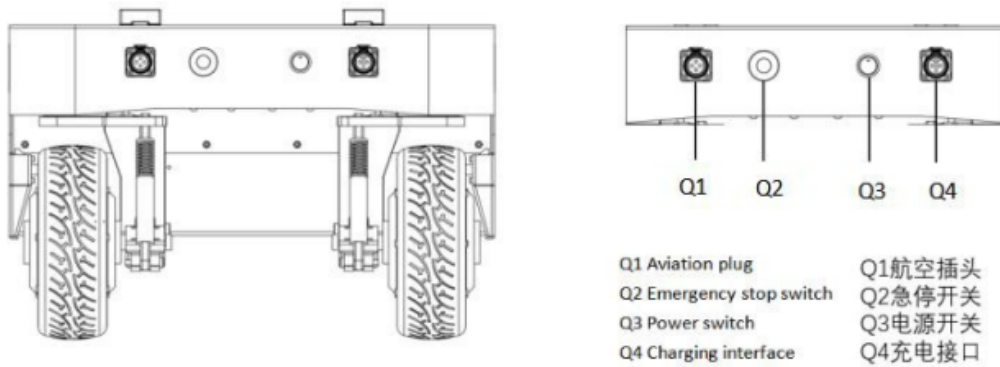
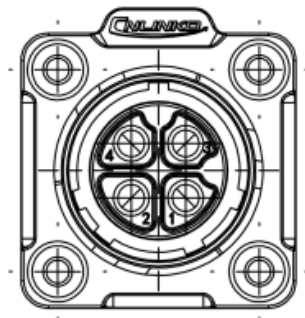

Figure 2.2 Back View of the RANGER MINI 3.0

The RANGER MINI 3.0 has a circular connector for expansion at its rear. The interface can be used to provide power for external equipment (the load current cannot exceed 15 A, and the voltage range is 46~50 V) and transfer information through its CAN communication interface. Its pins

are defined in the figure below. Please note that its power supply is subject to internal control. When the battery voltage is lower than the safe level, it will actively cut off the power supply. Therefore, users need to pay attention to the low voltage alarm of the RANGER MINI 3.0 before reaching the critical voltage. Do not forget to charge the RANGER MINI 3.0 after use.



Pin Number	Pin Type	Function and Definition	Note
------------	----------	-------------------------	------

1	Power supply	VCC	Positive terminal. The voltage range is 46~50 V The load current cannot exceed 15 A.
2	Power supply	GND	Negative terminal
3	CAN	CAN_H	CAN H (High)
4	CAN	CAN_L	CAN L (Low)

Figure 2.3 Pin descriptions of the circular connector

2.3 Remote Control Instructions



Figure 2.4 Introduction of the remote control

As shown in the figure above, the functions of the buttons are defined as follows: SWB is the control mode, switch to the top is the command control mode, dialed to the middle or down is the remote control mode; SWA is the light control switch, dialed to the bottom is to turn off the light (need SWB first enters the remote control mode); SWC controls the parking mode. When SWC is turned to the bottom, it is the parking mode, and the four-wheel four-steering is X-shaped at this time Locking.

SWD is the switch for Motion mode:

Moving SWD to the top is ① front and rear Ackerman mode (the left joystick controls the speed, and the right joystick controls the steering angle) + ② spin mode (the left joystick does not move, the right joystick controls the spin direction)

Moving SWD to the bottom is the tilt motion mode: the left joystick controls the speed, and the right joystick controls the steering angle (the maximum angle is 90°, which makes the RANGER MINI 3.0 move laterally);

Voltage/current drive mode switching :

Firstly, switch SWC to the bottom to let the robot enter parking mode. Then switch SWB to the bottom, and then switch SWC to the top to exit the parking mode.

Zero point calibration:

SWA=DOWN; SWB=UP; SWD=DOWN;

The four positions of the left joystick represent the four corresponding steering motors(For example: Left move to upper right refers to calibrate the upper right steering motor, and upper left refers to the upper left steering motor).

The right joystick adjusts the angle in the left and right directions.

And the left roller can adjust the positions in two directions cumulatively.

SWC is the sensitivity adjustment: DOWN→coarse adjustment MID→middle adjustment UP→fine adjustment

key1: Set the current position as zero point.

Pressing KEY1 in any case = forcibly clear all errors of the RANGER MINI 3.0.

Attention! To be used only in special cases where safety is guaranteed.

POWER is the power button. Press and hold it to power on.

Basic operation process of remote control:

Before starting, you need to ensure that the wheels and chassis of RANGERMINI are parallel and facing forward.

After starting the RANGERMINI 3.0 mobile robot chassis normally, start the remote controller, switch the SWB to remote control mode, and then control the movement of the RANGERMINI platform through the remote controller.

Remote control battery replacement instructions:

The FS remote control uses 5(AA) batteries as its energy supply. When the remote control display interface Remoter is relatively low, it means that the battery power of the remote control is too low. At this time, you need to open the battery cover on the back of the remote control and replace the battery.

3 Usage and Development

This part mainly introduces the basic operation and usage of the RANGER MINI 3.0, and how to carry out secondary development through the external CAN interface and the CAN bus protocol.

3.1 Operation

Check

Check the RANGER MINI 3.0 status

Check whether there is any obvious abnormality in the RANGER MINI 3.0; if so, please contact after-sales support;

When using it for the first time, check whether the e-stop switch(Q2) in the rear electrical panel is pressed, if pressed, please release it.

PAY ATTENTION: After the emergency stop button is released, you need to manually press key1 to clear the emergency stop error in remote control mode. In command mode, you need to clear the emergency stop error through the clear error command.

Power on and off

The Q3 button on the tail is a switch button. When pressed, the power is turned on and the robot is powered on.

Charge

Check the battery voltage, the normal voltage range is 45-54V, if the front light flashes, it means the battery voltage is too low, please charge it in time. This product is equipped with a 10A charger by default. Insert the plug of the charger into the Q4 charging socket on the back of the chassis, connect the charger to the power supply, and turn on the switch on the charger to enter the charging state.

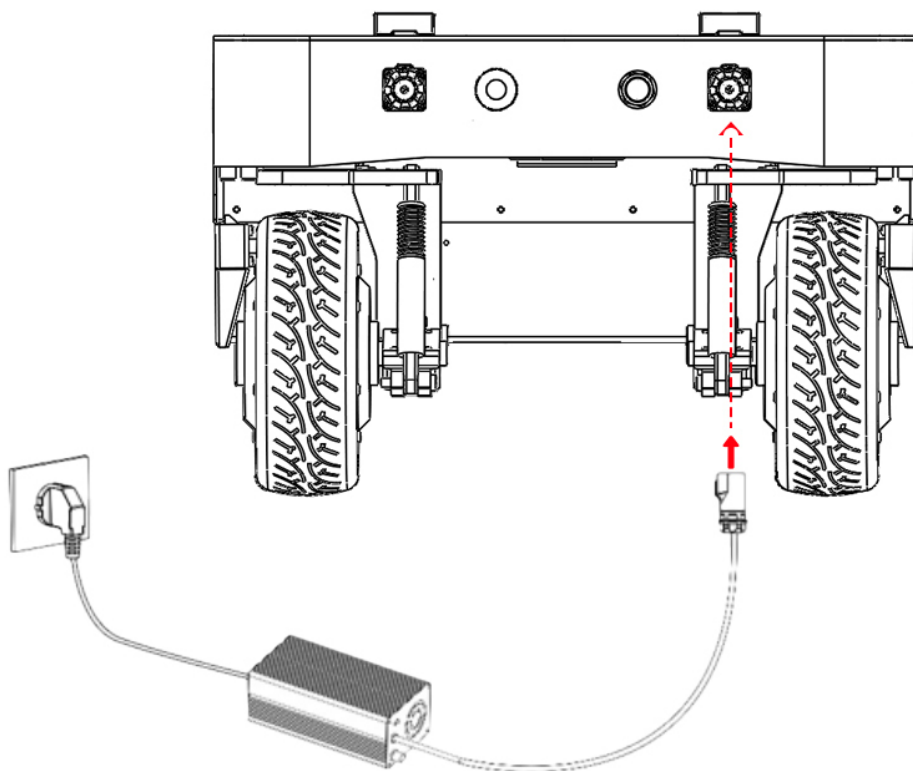

Battery replacement

RANGERMINI is equipped with a 48v24ah battery. During operation, when the battery power is too low, we can open the battery panel on the right side to quickly replace the battery.

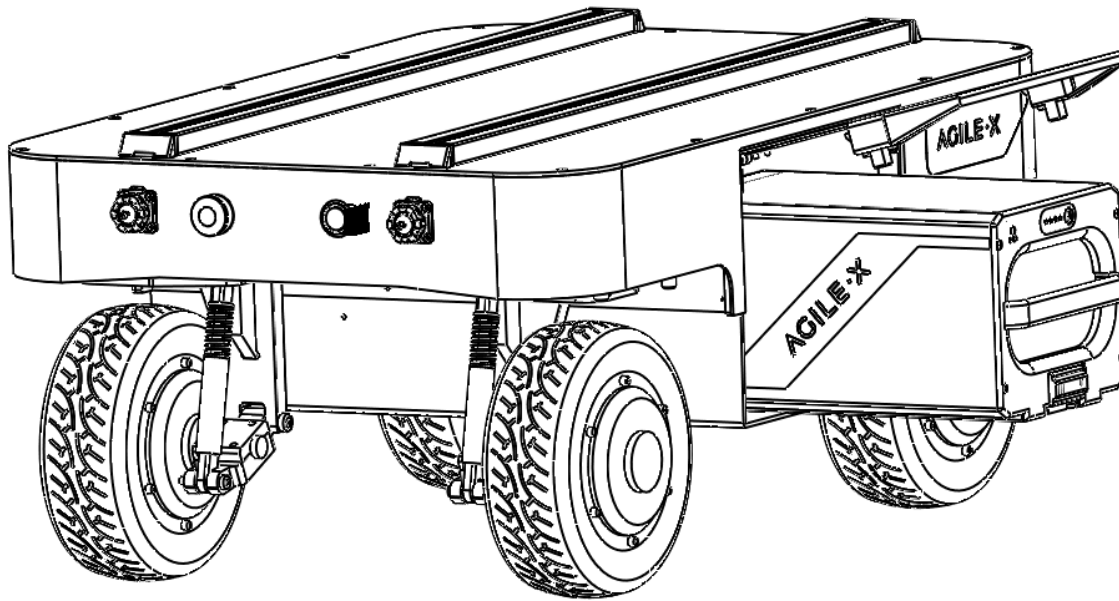

Connection of the CAN Cable

The 4WD chassis is shipped with an circular connector male head. The definition of its lines can refer to the figure below:



Figure 3.1 Overview of the circular connector

Implementation of CAN command control

Start the RANGER MINI 3.0 normally, turn on the remote control, and then switch the SWB to the command control mode (move SWB to the top). At this time, the RANGER MINI 3.0 will accept commands from the CAN bus, and the host can also analyze the status of the RANGER MINI 3.0 using the feedbacked real-time data through the CAN bus. Refer to the CAN communication protocol for details. (By default, when the chassis is started and the remote control is not started.)

3.2 CAN Communication Protocol

The CAN communication protocol in this product is CAN2.0B standard, its communication baud rate is 500 K, and its message format is the MOTOROLA format. Through the external CAN interface, users can switch the control model and control the linear speed and steering angle of the RANGER. The RANGER MINI 3.0 will real-time feedback the current movement status information (including the integrated movement information of the vehicle and the detailed movement information of each wheel) and the system status information (including self-diagnostic error codes).

Command	System Status Feedback Command			
Node for sending	Node for receiving	ID	Period (ms)	Receive timeout (ms)
Drive-by-wire chassis	Decision-making and control unit	0x211	20ms	None
Data length	0x08			
Byte	Meaning	Data type	Note	
byte [0]	Current vehicle status	unsigned int8	0x00 The system is normal 0x02 The system is abnormal	
byte [1]	Control mode	unsigned int8	0x00 Standby mode 0x01 Command control mode 0x03 Remote control mode	
byte [2]	High order byte of battery voltage	unsigned int16	Actual voltage X 10 (the unit is 0.1 V)	
byte [3]	Low order byte of battery voltage			

byte [4]	Highest order byte of error message	unsigned int32	Refer to the error message table for details
byte [5]	High order byte of error message		
byte [6]	Low order byte of error message		
byte [7]	Lowest order byte of error message		

Table 1 Error message table

Error message		
Byte	Bit	Meaning
byte [4]	bit [0]	Reserved, the default value is 0.
	bit [1]	Reserved, the default value is 0.
	bit [2]	Reserved, the default value is 0.
	bit [3]	Reserved, the default value is 0.
	bit [4]	Reserved, the default value is 0.
	bit [5]	Reserved, the default value is 0
	bit [6]	Reserved, the default value is 0
	bit [7]	Reserved, the default value is 0
byte [5]	bit [0]	Right front steering zero point calibration status (0: unfaulty; 1: faulty)

	bit [1]	Right rear steering zero point calibration status (0: unfaulty; 1: faulty)
	bit [2]	Left rear steering zero point calibration status (0: unfaulty; 1: faulty)
	bit [3]	Left front steering zero point calibration status (0: unfaulty; 1: faulty)
	bit [4]	Steering calibration timeout (0: unfaulty; 1: faulty)
	bit [5]	Reserved, the default value is 0
	bit [6]	Reserved, the default value is 0
	bit [7]	Reserved, the default value is 0
byte [6]	bit [0]	Driver status (0: unfaulty; 1: faulty)
	bit [1]	Reserved, the default value is 0
	bit [2]	No. 5 motor driver communication status (0: unfaulty; 1: faulty)
	bit [3]	No. 6 motor driver communication status (0: unfaulty; 1: faulty)
	bit [4]	No. 7 motor driver communication status (0: unfaulty; 1: faulty)
	bit [5]	No. 8 motor driver communication status (0: unfaulty; 1: faulty)
	bit [6]	Over temperature protection status (0: normal; 1: triggered)
	bit [7]	Over current protection status (0: normal; 1: triggered)
byte [7]	bit [0]	Battery undervoltage status (0: normal; 1: triggered)
	bit [1]	Overvoltage protection (0: no fault 1: fault)

	bit [2]	Remote control lost connection protection status (0: normal; 1: triggered)
	bit [3]	No. 1 motor driver communication status (0: unfaulty; 1: faulty)
	bit [4]	No. 2 motor driver communication status (0: unfaulty; 1: faulty)
	bit [5]	No. 3 motor driver communication status (0: unfaulty; 1: faulty)
	bit [6]	No. 4 motor driver communication status (0: unfaulty; 1: faulty)
	bit [7]	Emergency stop is triggered, (0: normal 1: trigger emergency stop)

The motion control feedback frame includes the current linear speed and steering angle of the vehicle.

The details of the protocol are as follows

Command	Motion Control Feedback Command			
Node for sending	Node for receiving	ID	Period (ms)	Receive timeout (ms)
Drive-by-wire chassis	Decision-making and control unit	0x221	20ms	None
Data length	0x08			
Byte	Meaning	Data type	Note	
byte [0] byte [1]	High order byte of speed Low order byte of speed	signed int16	Actual speed X 1000 (the unit is 0.001 m/s)	
byte [2] byte [3]	High order byte of spin speed Low order byte of spin speed	signed int16	Angular velocity of chassis rotation, unit 0.001rad/s	

byte [4]	Reserved	-	0X00
byte [5]	Reserved	-	0X00
byte [6] byte [7]	High order byte of steering angle Low order byte of steering angle	signed int16	Actual steering angle X 1000 (the unit is 0.001 rad)

The motion control frame includes the linear speed control command and the steering angle control command. The details of the protocol are as follows:

Command		Motion Control Command		
Node for sending	Node for receiving	ID	Period (ms)	Receive timeout (ms)
Decision-making and control unit	Node for the chassis	0x111	20ms	500ms
Data length	0x08			
Byte	Meaning	Data type	Note	
byte [0] byte [1]	High order byte of linear speed Low order byte of linear speed	signed int16	Speed of the vehicle, whose unit is mm/s (valid value + -2000; valid value + -1000 when the steering angle > 20°; taking effect in front and rear Ackerman mode and oblique motion mode) Forward direction is positive	
byte [2] byte [3]	High order byte of spin speed Low order byte of spin speed	signed int16	Angular velocity of chassis rotation, unit 0.001rad/s (Valid value +-3259, counterclockwise rotation is positive value)	
byte [4]	Reserved	-	-	

byte [5]			
byte [6]	High order byte of steering angle	signed int16	Steering inner corner angle unit: 0.001rad (effective value front and rear Ackerman mode + -698, oblique mode + - 1571) Left turn direction is positive
byte [7]	Low order byte of steering angle		

As shown in Figure 3.2.1, when the RANGER MINI 3.0 is in front and rear Ackerman mode, the feedback steering angle is $(\alpha+\beta)/2$, left steering is negative, and right steering is positive; the feedback speed is the average value of the four wheels' speed (that is, the linear speed of the chassis), reversing is negative, and moving forward is positive. If you need to check the detailed steering angle and speed of each wheel, please refer to 0X271 and 0X281 feedback frames.

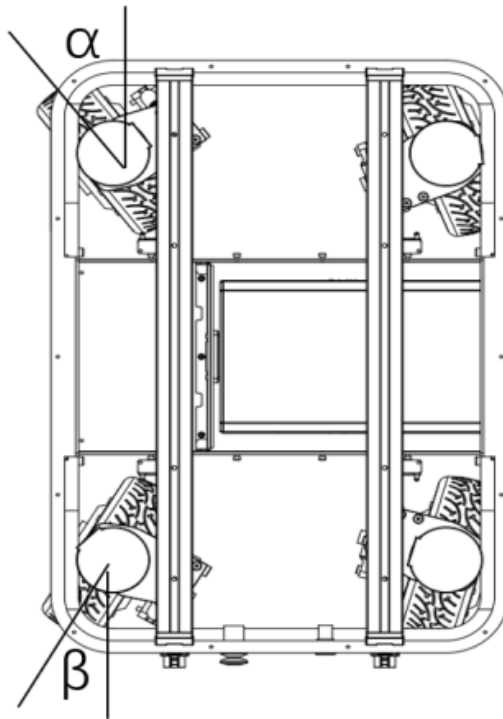

Figure 3.2.1 The Ackerman structure of the RANGER

As shown in Figure 3.2.2, when the RANGER MINI 3.0 is in oblique motion mode, the feedback steering angle is $(\alpha_1+\alpha_2+\alpha_3+\alpha_4)/4$, left steering is negative, and right steering is positive; the feedback linear speed is the average value of the four wheels' speed, reversing is negative, and moving forward is positive. If you need to check the detailed steering angle and speed of each wheel, please refer to the 0x271 and 0x281 feedback frames.

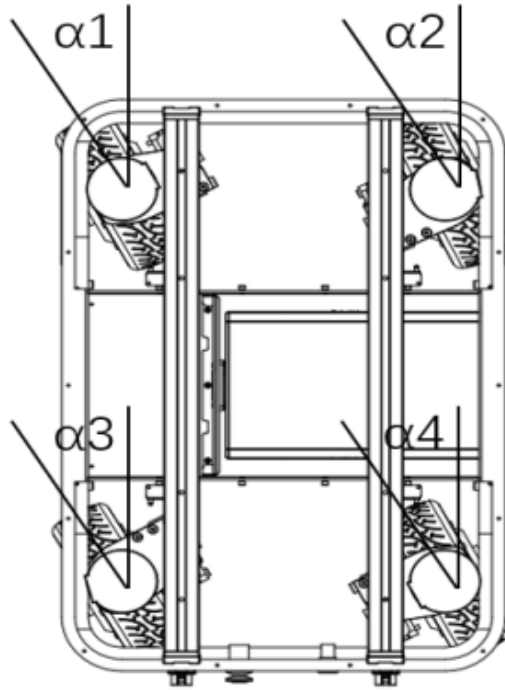

Figure 3.2.2 Wheels control of the RANGER MINI 3.0 in oblique motion mode

When the chassis is in the spin mode, the steering angle is a constant value, which cannot be changed. At this time, the feedback steering angle is the average value of the absolute values of α_1 , α_2 , α_3 , and α_4 . The spinning speed of the chassis can be changed by commands, and counterclockwise spinning is positive.

The mode setting frame is used to set the terminal control interface, and the details of the protocol are as follows.

Command		Control Command		
Node for sending	Node for receiving	ID	Period (ms)	Receive timeout (ms)
Decision-making and control unit	Node for the chassis	0x421	None	None
Data length	0x01			
Byte	Meaning	Data type	Note	
byte [0]	Control mode	unsigned int8	0x00 Standby mode 0x01 CAN command control mode Boot into standby mode by default	

Control mode description: when the chassis is powered on and the remote control is not connected, the control mode is standby mode. At this time, the chassis only receives control mode commands and does not respond to other commands. To control the chassis using CAN, you need to switch control mode to CAN command control mode first. If the remote control is turned on, the remote control has the highest priority, which can block the control command and switch the control mode.

Current control and voltage control switching control command (**Note: the switching of voltage/current driving mode can only be completed in X-shaped parking**)

Command		Control command		
Node for sending	Node for receiving	ID	Period (ms)	Receive timeout (ms)
Decision-making and control unit	Node for the chassis	0x423	None	None
Data length	0x01			
Byte	Meaning	Data type	Note	
byte [0]	Control mode	unsigned int8	0x00 The chassis enters current control mode (default power-on current control). In this state, the servo is relatively soft, and the noise reduction effect is good. 0x01 The chassis enters voltage control mode. In this state, the servo is relatively stiff, the noise is louder, and the obstacle-crossing ability is stronger.	

The status setting frame is used to clear system errors, and the details of the protocol are as follows.

Command		Control Command		
Node for sending	Node for receiving	ID	Period (ms)	Receive timeout (ms)
Decision-making and control unit	Node for the chassis	0x441	None	None
Data length	0x01			

Byte	Meaning	Data type	Note
byte [0]	Error clearing command	unsigned int8	0x00 Clear all non-critical faults 0x01~0x08 Clear the communication faults of No. 1~8 motor drivers respectively 0x09 Clear the battery undervoltage fault and try to restore the power supply 0x0a Clear remote control signal loss fault 0x0b~0x0e Clear the steering calibration fault of No. 5~8 motors respectively 0x0f Clear over current fault 0x10 Clear over temperature fault

Sample data, the following data is only for testing, **command control mode needs to be enabled before use.**

1. The chassis moves forward at 0.15m/s

byte [0]	byte [1]	byte [2]	byte [3]	byte [4]	byte [5]	byte [6]	byte [7]
0x00	0x96	0x00	0x00	0x00	0x00	0x00	0x00

2. The chassis turns 10°

byte [0]	byte [1]	byte [2]	byte [3]	byte [4]	byte [5]	byte [6]	byte [7]
0x00	0x00	0x00	0x00	0x00	0x00	0x03	0xe8

In addition to the status of the chassis itself, its feedback information also includes the steering angle and speed of the four wheels, the current of the motor, the encoder information, and the temperature information.

The details of the protocol are as follows:

PS: The eight motor numbers of the chassis are: No. 1 is the right front wheel motor, No. 2 is the right rear wheel motor, No. 3 is the left rear wheel motor, No. 4 is the left front wheel motor, No. 5 is the right front steering motor, No. 6 is the right rear steering motor, No. 7 is the left rear steering motor, and No. 8 is the left front steering motor.

Feedback information of speed, current, and position of motor

Command		High-speed feedback information frame for motor driver		
Node for sending	Node for receiving	ID	Period (ms)	Receive timeout (ms)

Drive-by-wire chassis	Decision-making and control unit	0x251~0x258	20ms	None
Data length	0x08			
Byte	Meaning	Data type	Note	
byte [0] byte [1]	High order byte of motor speed Low order byte of motor speed	signed int16	The current speed of the motor, whose unit is RPM (Revolutions Per Minute)	
byte [2] byte [3]	High order byte of motor current Low order byte of motor current	signed int16	The present current of the motor, whose unit is 0.1 A	
byte [4] byte [5] byte [6] byte [7]	Highest order byte of position High order byte of position Low order byte of position Lowest order byte of position	signed int32	The current position of the motor, whose unit is the number of pulses	

Feedback of temperature voltage and status of motor

Command		Low-speed information feedback frame for motor driver		
Node for sending	Node for receiving	ID	Period (ms)	Receive timeout (ms)
Drive-by-wire chassis	Decision-making and control unit	0x261~0x268	100ms	None
Data length	0x08			
Byte	Meaning	Data type	Note	

byte [0]	High order byte of driver voltage	unsigned int16	The current driver voltage, whose unit is 0.1 V
byte [1]	Low order byte of driver voltage		
byte [2]	High order byte of drive temperature	signed int16	The unit is 1 °C.
byte [3]	Low order byte of driver temperature		
byte [4]	Motor temperature	signed int8	The unit is 1 °C. (Invalid value for RANGM series and can be ignored)
byte [5]	Driver status	unsigned int8	See Table 2 for details
byte [6]	Reserved	-	0X00
byte [7]	Reserved	-	0X00

Table 2 Driver status

Byte	Bit	Meaning
byte[5]	bit[0]	Power supply voltage status (0: normal; 1: too low)
	bit[1]	Motor temperature status (0: normal; 1: over temperature)
	bit[2]	The current status of the driver(0: normal; 1: over-current)
	bit[3]	Driver temperature status (0: normal; 1: over temperature)
	bit[4]	Sensor status (0: Normal; 1: Abnormal)
	bit[5]	Driver status (0: Normal; 1: Abnormal)
	bit[6]	Drive enable status (0: enable; 1: disable)
	bit[7]	Reserved

Steering angle feedback of four wheels

Command	Information feedback frame of four wheels' steering angle
---------	---

Node for sending	Node for receiving	ID	Period (ms)	Receive timeout (ms)
Drive-by-wire chassis	Decision-making and control unit	0x271	20ms	None
Data length	0x08			
Byte	Meaning	Data type	Note	
byte [0] byte [1]	High order byte of steering angle of No. 5 motor Low order byte of steering angle of No. 5 motor	signed int16	The Current steering angle, whose unit is 0.001 rad	
byte [2] byte [3]	High order byte of steering angle of No. 6 motor Low order byte of steering angle of No. 6 motor	signed int16	The Current steering angle, whose unit is 0.001 rad	
byte [4] byte [5]	High order byte of steering angle of No. 7 motor Low order byte of steering angle of No. 7 motor	signed int16	The Current steering angle, whose unit is 0.001 rad	
byte [6] byte [7]	High order byte of steering angle of No. 8 motor Low order byte of steering angle of No. 8 motor	signed int16	The Current steering angle, whose unit is 0.001 rad	

Rotational speed feedback of four wheels

Command		Information feedback frame of four wheels' rotational speed		
Node for sending	Node for receiving	ID	Period (ms)	Receive timeout (ms)
Drive-by-wire chassis	Decision-making and control unit	0x281	20ms	None
Data length	0x08			
Byte	Meaning	Data type	Note	
byte [0] byte [1]	High order byte of rotational speed of No. 1 motor Low order byte of rotational speed of No. 1 motor	signed int16	The current rotational speed, whose unit is mm/s	
byte [2] byte [3]	High order byte of rotational speed of No. 2 motor Low order byte of rotational speed of No. 2 motor	signed int16	The current rotational speed, whose unit is mm/s	
byte [4] byte [5]	High order byte of rotational speed of No. 3 motor Low order byte of rotational speed of No. 3 motor	signed int16	The current rotational speed, whose unit is mm/s	
byte [6] byte [7]	High order byte of rotational speed of No. 4 motor	signed int16	The current rotational speed, whose unit is mm/s	

	Low order byte of rotational speed of No. 4 motor		
--	---	--	--

The motion mode switching command is used to change motion model of the chassis, and the details of the protocol are as follows

Command		Current motion mode feedback command		
Node for sending	Node for receiving	ID	Period (ms)	Receive timeout (ms)
Drive-by-wire chassis	Decision-making and control unit	0x291	20ms	None
Data length	0x02			
Byte	Meaning	Data type	Note	
byte [0]	Current motion mode	unsigned int8	0x00 front and rear Ackerman mode 0x01 oblique motion mode 0x02 spin mode 0x03 Parking mode	
byte [1]	Whether the chassis is in the process of switching the motion model	unsigned int8	0x00 switching is completed. 0x01 in the process of switching motion mode The chassis does not respond to speed control commands in the process of switching motion mode.	

The motion mode switching command is used to change motion model of the chassis, and the details of the protocol are as follows

Command		Control command		
Node for sending	Node for receiving	ID	Period (ms)	Receive timeout (ms)
Decision-making and control unit	Node for the chassis	0x141	None	None
Data length	0x01			
Byte	Meaning	Data type	Note	
byte [0]	Motion mode	unsigned int8	0x00 front and rear Ackerman mode (default) 0x01 oblique motion mode 0x02 spin mode 0x03 Parking mode	

The lighting control command is as follows.

Command		Light control command		
Node for sending	Node for receiving	ID	Period (ms)	Receive timeout(ms)
Decision-making and control unit	Node for the chassis	0x121	20ms	500ms
Data length	0x08			
Byte	Meaning	Data type	Note	
byte [0]	Lighting control enable flag	unsigned int8	0x00 Control command is invalid 0x01 Light control is enabled	
byte [1]	Light mode	unsigned int8	0x00 Always off 0x01 Always on	
byte [2]	Reserved	--	0x00	
byte [3]	Reserved	--	0x00	
byte [4]	Reserved	--	0x00	

byte [5]	Reserved	--	0x00
byte [6]	Reserved	--	0x00
byte [7]	Reserved	--	0x00

The lighting control feedback frame is as follows:

Command	Light control feedback command			
Node for sending	Node for receiving	ID	Period (ms)	Receive timeout(ms)
Node for the chassis	Decision-making and control unit	0x231	20ms	无
Data length	0x08			
Byte	Meaning	Data type	Note	
byte [0]	Current lighting control enable flag	unsigned int8	0x00 Control command is invalid 0x01 Light control is enabled	
byte [1]	Current light mode	unsigned int8	0x00 Always off 0x01 Always on	
byte [2]	Reserved	unsigned int8	0x00	
byte [3]	Reserved	--	0x00	
byte [4]	Reserved	--	0x00	
byte [5]	Reserved	--	0x00	
byte [6]	Reserved	--	0x00	
byte [7]	Count	unsigned int8	0~255 loop count, the count is incremented every time an instruction is sent.	

The odometer information feedback frame is as follows

Front wheel

Command	Front wheel mileage feedback			
Node for sending	Node for receiving	ID	Period (ms)	Receive timeout (ms)

Drive-by-wire chassis	Decision-making and control unit	0x311	20ms	None
Data length	0x08			
Byte	Description	Data type	Note	
byte [0] byte [1] byte [2] byte [3]	Highest order byte of front left wheel odometer Sub-high order byte of front left wheel odometer Second low order byte of front left wheel odometer Lowest order byte of front left wheel odometer	signed int32	Chassis left wheel odometer feedback, Unit: mm	
byte [4] byte [5] byte [6] byte [7]	Highest order byte of front right wheel odometer Sub-high order byte of front right wheel odometer Second low order byte of front right wheel odometer Lowest order byte of front right wheel odometer	signed int32	Chassis right wheel odometer feedback, Unit: mm	

Rear wheel

Command	Rear wheel mileage feedback			
Node for sending	Node for receiving	ID	Period (ms)	Receive timeout (ms)

Drive-by-wire chassis	Decision-making and control unit	0x312	20ms	None
Data length	0x08			
Byte	Description	Data type	Note	
byte [0] byte [1] byte [2] byte [3]	Highest order byte of rear left wheel odometer Sub-high order byte of rear left wheel odometer Second low order byte of rear left wheel odometer Lowest order byte of rear left wheel odometer	signed int32	Chassis left wheel odometer feedback, Unit: mm	
byte [4] byte [5] byte [6] byte [7]	Highest order byte of rear right wheel odometer Sub-high order byte of rear right wheel odometer Second low order byte of rear right wheel odometer Lowest order byte of rear right wheel odometer	signed int32	Chassis right wheel odometer feedback, Unit: mm	

The remote controller information feedback frame is as follows

Command		Remote controller information feedback		
Node for sending	Node for receiving	ID	Period (ms)	Receive timeout (ms)

Drive-by-wire chassis	Decision-making and control unit	0x241	20ms	None
Data length	0x08			
Byte	Description	Data type	Note	
byte [0]	Remote control SW feedback	unsigned int8	bit[0-1]: SWA:2- Up 3-Down bit[2-3]: SWB : 2-Up 1-Middle 3-Down bit[4-5]: SWC : 2-Up 1-Middle 3-Down bit[6-7]: SWD: 2-Up 3-Down	
byte [1]	Right joystick left and right	unsigned int8	Range:[-100,100]	
byte [2]	Right joystick up and down	unsigned int8	Range:[-100,100]	
byte [3]	Left joystick up and down	unsigned int8	Range:[-100,100]	
byte [4]	Left joystick left and right	unsigned int8	Range:[-100,100]	
byte [5]	Left knob VRA	unsigned int8	Range:[-100,100]	
byte [6]	Reserved	--	0x00	
byte [7]	Count check	unsigned int8	0-255 Cycle count	

The feedback data of BMS for all batteries, and the details of the protocol are as follows

Command		The feedback data of BMS		
Node for sending	Node for receiving	ID	Period (ms)	Receive timeout (ms)
Drive-by-wire chassis	Decision-making and control unit	0x361	500ms	None

Data length	0x08			
Byte	Meaning	Data type	Note	
byte [0]	Battery SOC (State of Charge)	unsigned int8	Range 0~100	
byte [1]	Battery SOH (State of Health)	unsigned int8	Range 0~100	
byte [2] byte [3]	High order byte of battery voltage Low order byte of battery voltage	unsigned int16	Unit: 0.01 V	
byte [4] byte [5]	High order byte of battery current Low order byte of battery current	signed int16	Unit: 0.1 A	
byte [6] byte [7]	High order byte of battery temperature Low order byte of battery temperature	signed int16	Unit: 0.1 °C	

Command		The feedback data of BMS		
Node for sending	Node for receiving	ID	Period (ms)	Receive timeout (ms)
Drive-by-wire chassis	Decision-making and control unit	0x362	500ms	None
Data length	0x04			
Byte	Meaning	Data type	Note	
byte [0]	Alarm Status 1	unsigned int8	BIT1: Overvoltage; BIT2: Undervoltage; BIT3: High temperature; BIT4: Low temperature; BIT7: Discharge overcurrent	

byte [1]	Alarm Status 2	unsigned int8	BIT0: Charging overcurrent
byte [2]	Warning Status 1	unsigned int8	BIT1: Overvoltage; BIT2: Undervoltage; BIT3: High temperature; BIT4: Low temperature; BIT7: Discharge overcurrent
byte [3]	Warning Status 2	unsigned int8	BIT0: Charging overcurrent

3.3 RANGER MINI 3.0 use manual for ROS

ROS (Robot Operating System) provides some standard operating system services, such as hardware abstraction, low-level device control, implementation of commonly used functionality, message-passing between processes, and package management. ROS is based on a graph architecture, where processing takes place in nodes that may receive, post, and multiplex various information (such as sensor data, control, state, planning, and other messages). Currently ROS mainly supports UBUNTU OS.

Development Preparation

Hardware Equipment

- CANlight CAN communication module X1
- Laptop X1
- AGILEX RANGER MINI 3.0 mobile robot chassis X1
- Paired remote control FS-i6s for the AGILEX RANGER MINI 3.0X1
- Circular connector on the rear of the AGILEX RANGER MINI 3.0

Tested Development Environment

- Ubuntu 18.04
- ROS melodic
- Git

Hardware Connection and Preparation

Pull out the CAN wires of the circular connector on the rear of RANGER MINI 3.0, and connect can_H and can_L wires of the CAN to the CAN_TO_USB adapter; power on the RANGER MINI 3.0; connect the CAN_TO_USB adapter to the USB port of the laptop. The wiring diagram is shown in the figure below.

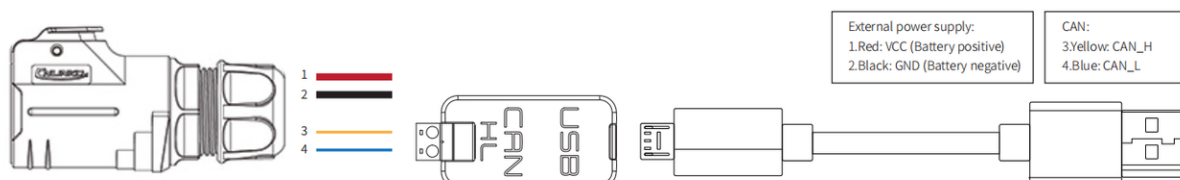

The CAN wiring diagram

ROS Installation and Environment Setup

安装具体可以参考<http://wiki.ros.org/kinetic/Installation/Ubuntu>

Please refer to <http://wiki.ros.org/kinetic/Installation/Ubuntu> for details

Test the Communication between CANABLE hardware and CAN

Setting CAN-TO-USB adaptor

- Enable gs_usb kernel module

∨

复制代码

```
sudo modprobe gs_usb
```

- Setting 500k Baud rate and enable can-to-usb adaptor

∨

复制代码

```
sudo ip link set can0 up type can bitrate 500000
```

- If no error occurred in the previous steps, you should be able to use the command to view the can device immediately

∨

复制代码

```
ifconfig -a
```

- Install and use can-utils to test hardware

∨

复制代码

```
sudo apt install can-utils
```

- If the can-to-usb has been connected to the BUNKER robot this time, and the car has been turned on, use the following commands to monitor the data from the BUNKER chassis

∨

复制代码

```
candump can0
```

Please refer to:

[1] https://github.com/agilexrobotics/agx_sdk

[2] https://wi-ki.rdu.im/_pages/Notes/Embedded-System/Linux/-can-bus-in-linux.html

AGILEX RANGER ROS PACKAGE download and compile

- Download ros package

[复制代码](#)

```
$ sudo apt install libasio-dev
$ sudo apt install ros-$ROS_DISTRO-teleop-twist-keyboard
```

- Clone compile hunter_ros code

[复制代码](#)

```
$ cd ~/catkin_ws/src
$ git clone --recursive https://github.com/agilexrobotics/ugv_sdk.git
$ git clone https://github.com/agilexrobotics/ranger_ros.git
$ cd ..
$ catkin_make
```

Please refer to: https://github.com/agilexrobotics/ranger_ros

Start the ROS node

- Start the based node

[复制代码](#)

```
roslaunch ranger_bringup ranger_minimal.launch
```

Note that the usb_to_can module equipped with Songling needs to be enabled before starting. The enabling command is as follows: `roslaunch ranger_bringup bringup_can2usb.bash`.

This command only needs to be executed once each time the usb_to_can module is powered on.

- Start the keyboard remote operation node

[复制代码](#)

```
roslaunch ranger_bringup ranger_teleop_keyboard.launch
```

Pay attention to the terminal printout and use the designated keys to control the RANGERMINI movement.

Github ROS development package directory and usage instructions

*_base:: The core node for the chassis to send and receive hierarchical CAN messages. Based on the communication mechanism of ros, it can control the movement of the chassis and read the status of the RANGERMINI through the topic.

*_msgs: Define the specific message format of the chassis status feedback topic.

*_bringup: startup files for chassis nodes and keyboard control nodes, and scripts to enable the usb_to_can module

3.4 Firmware Upgrade

In order to facilitate users to upgrade the firmware version used by RANGERMINI 3.0 and bring customers a more complete experience, RANGERMINI 3.0 provides a firmware upgrade hardware interface and corresponding client software.

Upgrade Preparation

- Agilex CAN debugging module X 1
- Micro USB cable X 1
- RANGERMINI 3.0 chassis X 1
- A computer (WINDOWS OS (Operating System)) X 1

Upgrade Process

1.Plug in the USBTOCAN module on the computer, and then open the AgxCandoUpgradeToolV1.3_boxed.exe software (the sequence cannot be wrong, first open the software and then plug in the module, the device will not be recognized).

2.Click the Open Serial button, and then press the power button on the car body. If the connection is successful, the version information of the main control will be recognized, as shown in the figure.

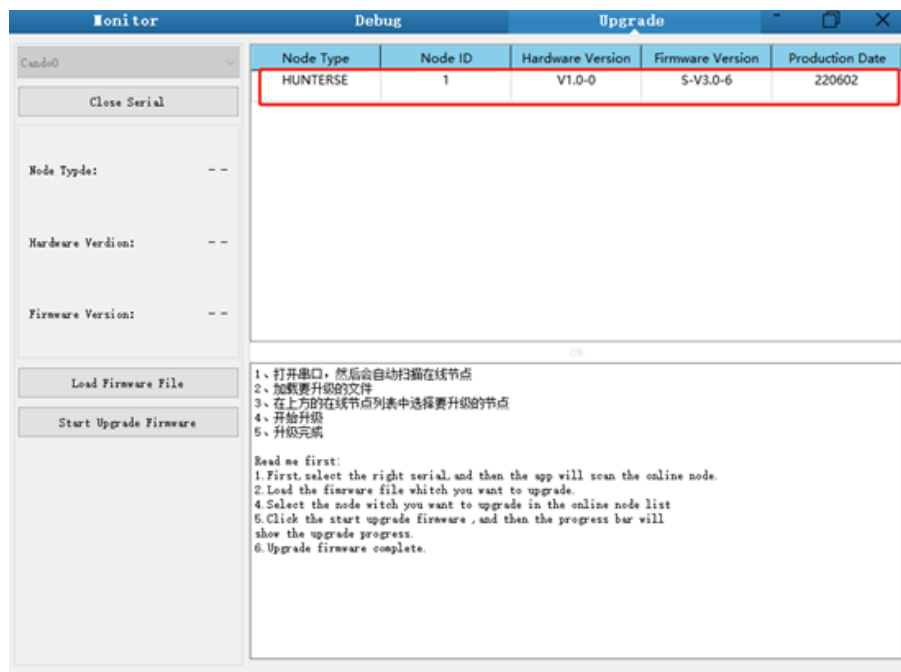

3.Click the Load Firmware File button to load the firmware to be upgraded. If the loading is successful, the firmware information will be obtained, as shown in the figure

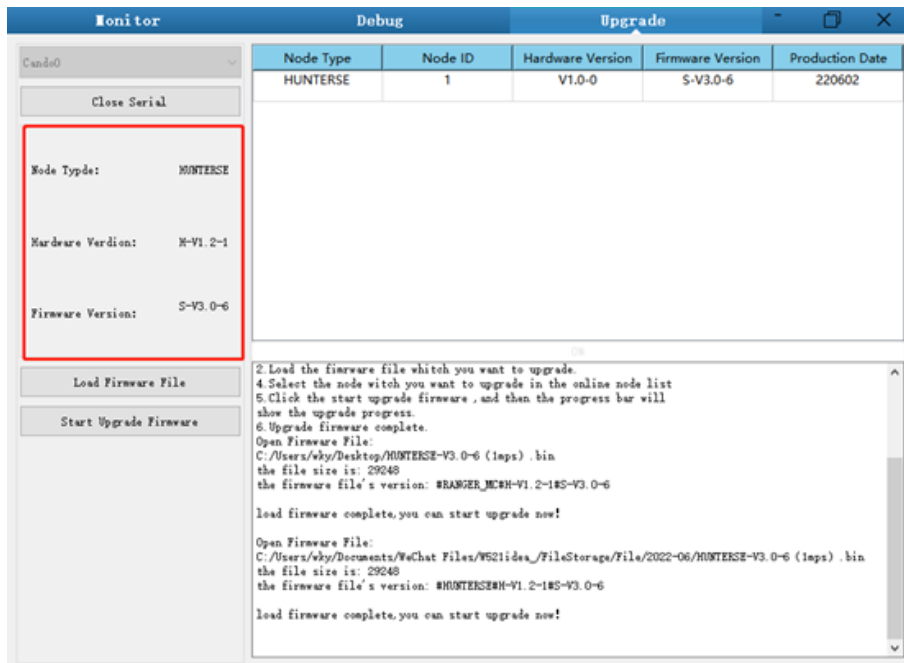

4. Click the node to be upgraded in the node list box, and then click Start Upgrade Firmware to start upgrading the firmware. After the upgrade is successful, a pop-up box will prompt.

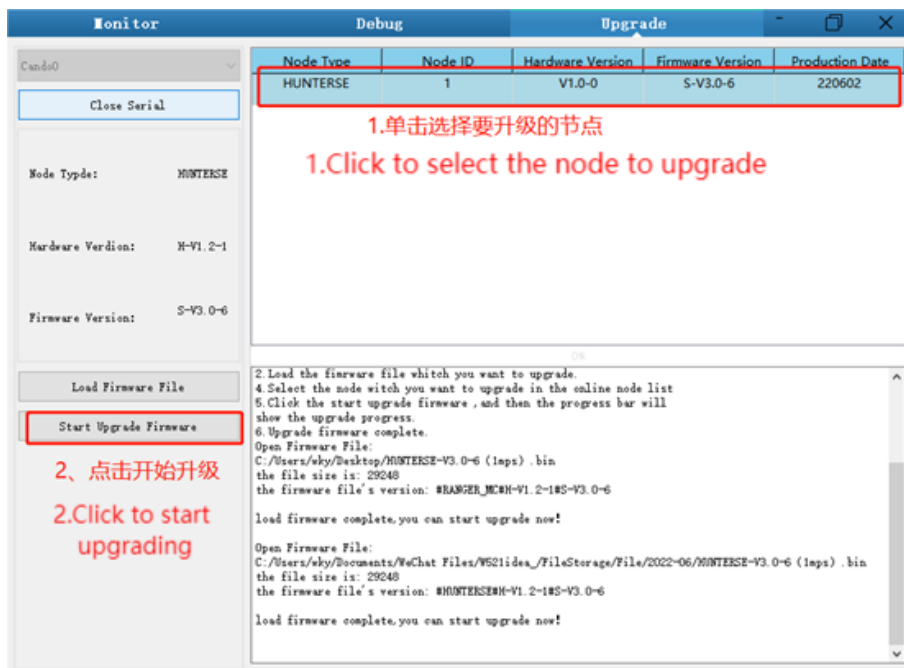

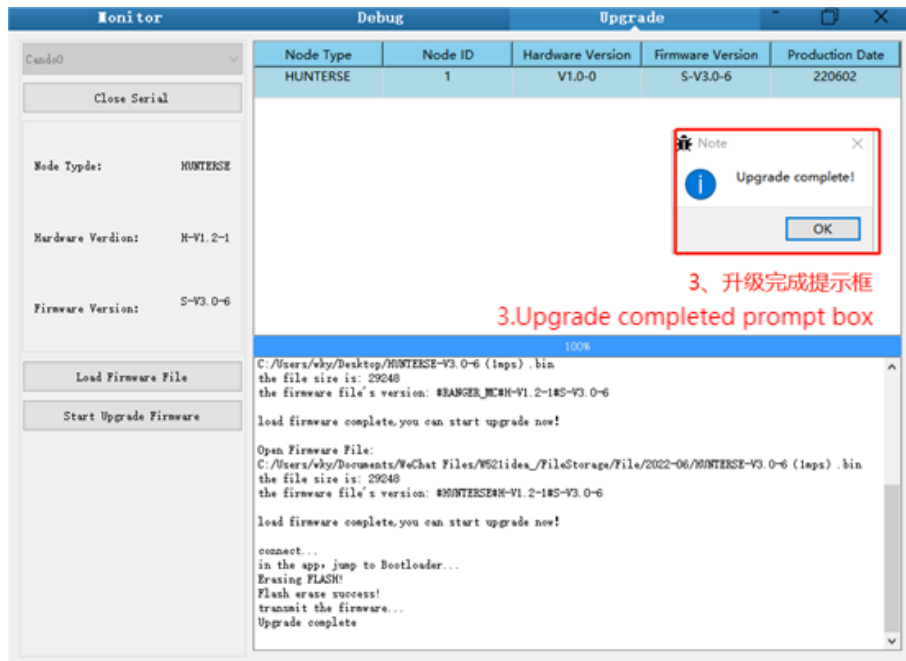

3、升级完成提示框

3.Upgrade completed prompt box

4 Product Size

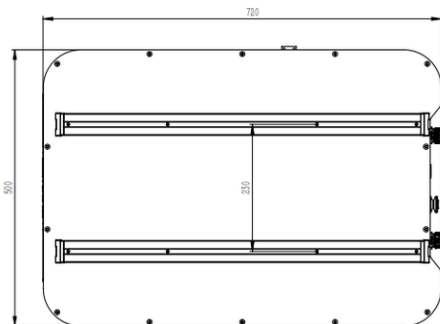
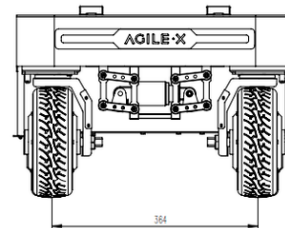
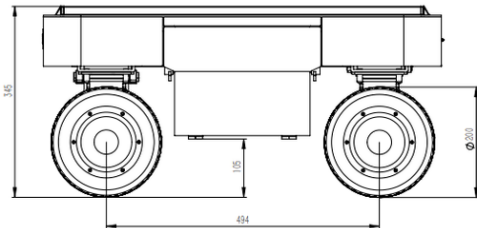

AGILE·X

松灵机器人(东莞)有限公司

WWW.AGILEX.AI

TEL:+86-0769-22892150

MOBILE:+86-19925374409

